

magneto

www.magnetopump.com



ACID PUMP PRODUCT CATALOGUE

Contents



Magneto Acid Pump



MAG DRIVE PUMPS

Mag drive pumps have a particular sealless design that is suitable for pumping corrosive and dangerous liquids thanks to the high chemical resistance and absence of leakage and emissions. The structure is really simple and it requires a very reduced maintenance with consequent save in terms of repairing and spare parts costs during the pump life. The external magnet placed on the drive shaft transmits the motion to the internal magnet connected to the impeller which rotates and moves the fluid through the pump.

Advantages

1. This special hermetic pump design prevents any leakage of fluid and fugitive emissions that, in case of chemicals, corrosive liquids, explosive and flammable fluids, could be very dangerous for people dealing with the pump and for the environment. So mag drive pumps allow to follow strict environmental and safety objectives required by many regulations. We shouldn't forget also that some liquids could be very expensive and their loss due to a seal failure may cause high unnecessary extra costs.
2. Mag drive pumps are very reliable and need very low maintenance thanks to their simple design. With normal working conditions these pumps can work without any kind of repair for more than a decade so their life cost is highly reduced. Nevertheless it's always better to check o-rings and bearings every one/two years just to be sure that there is no wearing.
3. The coupling is very easy because there is no need for a motor/pump alignment.

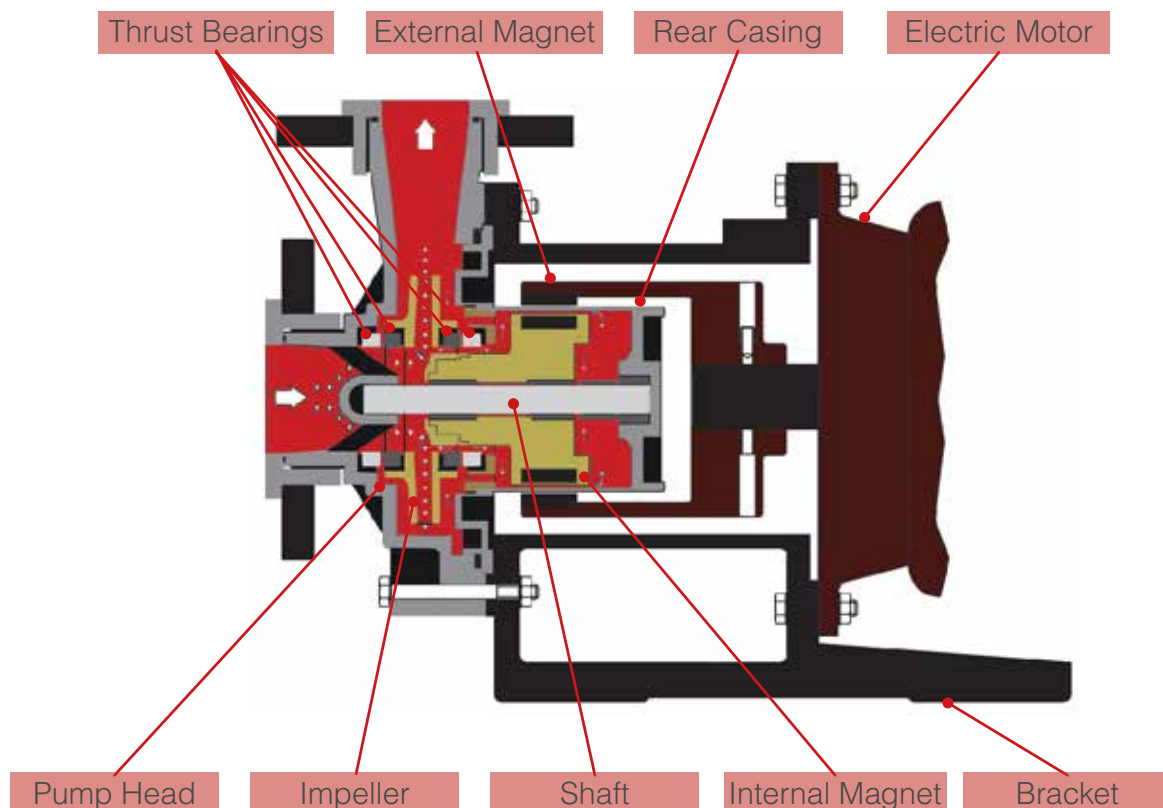

SEAL-LESS MAG DRIVE CENTRIFUGAL PUMPS

In seal-less magnetic drive centrifugal pumps, the external magnet is directly connected to the motor shaft and it transmits the torque to the internal magnet.

The magnetic field created produces a rotation without physical contact between the parts so the impeller spins and moves the fluid. The rear casing is placed between the two magnet joints and it hermetically closes the hydraulic part from the motor.

Magneto can supply three different models of mag drive centrifugal pumps:

MG PP / PVDF

- Thermoplastic pumps made in PP or PVDF
- Capacity up to 45 m³/h.
- Head up to 33 mlc.
- Injection molded parts.

MGXL

- Thermoplastic pumps made in PP or PVDF
- Capacity up to 130 m³/h.
- Head up to 48 mlc.
- Pump head machined from a block.

MG SS316

- Metallic pumps made in stainless steel AISI316.
- Capacity up to 32 m³/h.
- Head up to: 24 mlc.

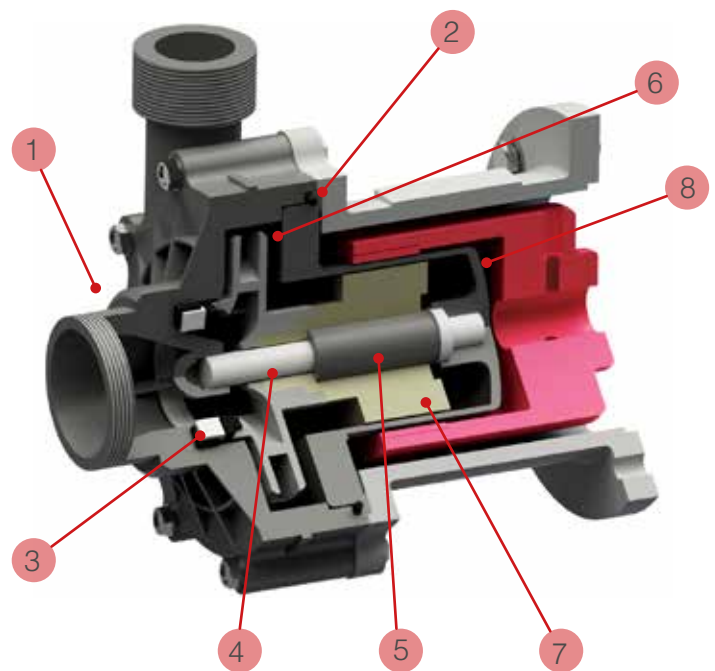

MATERIALS IN CONTACT WITH THE LIQUID			
Part Number / Description	Centrifugal Pumps		
	MG PP / PVDF	MGXL	MG SS316
1 - Pump Head	PP or PVDF	PP or PVDF	AISI 316
2 - O-Ring	EPDM or Viton	EPDM or Viton	EPDM or Viton
3 - Casing Thrust Bush	Ceramic Al ₂ O ₃ + EPDM or Viton	Ceramic Al ₂ O ₃ + EPDM or Viton	PTFEC
4 - Shaft	Ceramic Al ₂ O ₃ %99,7	Ceramic Al ₂ O ₃ 99,7%	HASTELLOY – C276
5 - Bearings	PTFEC	PTFEC	PTFEC
6 - Impeller	PP or PVDF	PP or PVDF	AISI 316
7 - Internal Magnet	PP or PVDF + NdFeB	PP or PVDF + NdFeB	AISI 316 + SmCo
8 - Rear Casing	PP or PVDF	PP or PVDF	AISI 316

THERMOPLASTIC MAG-DRIVE CENTRIFUGAL PUMPS

Mag drive centrifugal pumps series MG PP/PVDF are made of thermoplastic materials (Polypropylene and PVDF) and are suitable for high corrosive liquids. Thanks to the innovative mag drive system, pumps model MG PP/PVDF reduce the risks of leakage and emissions and the maintenance costs. The transmission of the motion occurs through magnetic joints without any mechanical seal and this design guarantees the maximum safety and efficiency. The pumped liquid has to be clean and without solids in suspension. High torque magnetic coupling NdFeB standard. Suitable for high corrosive liquids.



Technical Features

Materials available: PP / PVDF

Materials in contact with the liquid;

Casing and impeller: PP/PVDF;

- O-ring: EPDM (Standard for PP pumps);
- Viton (Standard for PVDF pumps);
- Static Shaft: Al₂O₃ 99,7 %; Bushing PTFEC.

Max flow: 45 m³/h; Max head 33 mlc.

Temperature: PP: max 70°C – PVDF: max 90 °C.

Max viscosity: 200 cSt.

Engine Power: It changes between 0.12 kW and 7.5 kW, depending on the model.

Connection Diameter: It changes between 1 "and 3" depending on the model.

Pressure rating: NP 6 at 20 °C.

Performance Curves 50 Hz – 2900 RPM

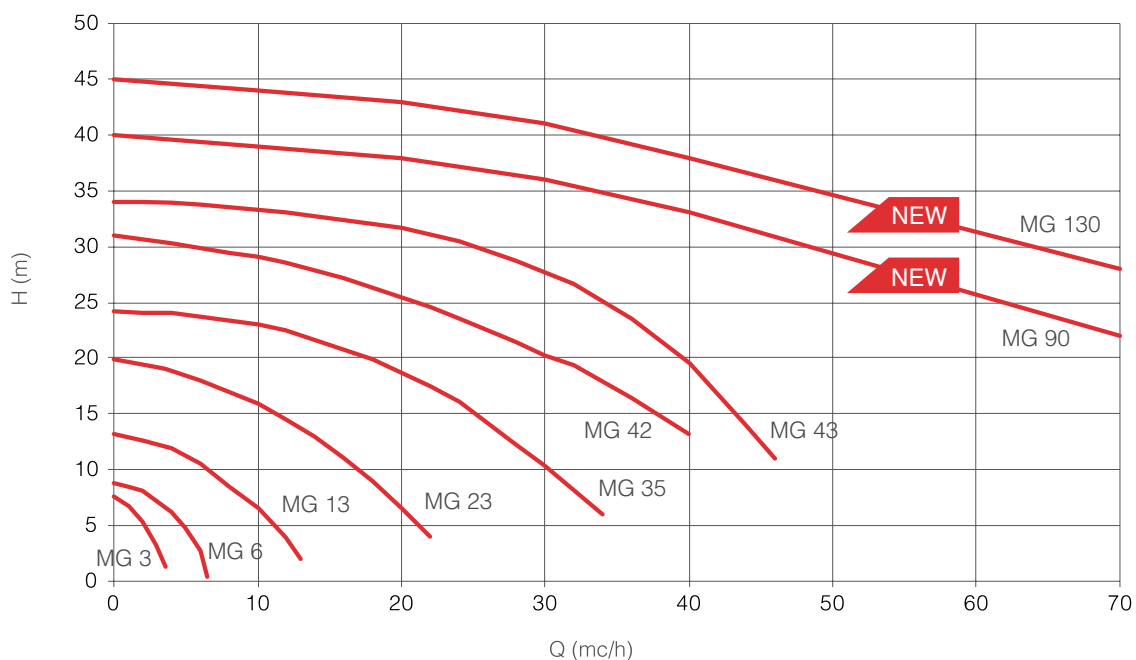

THERMOPLASTIC MAG-DRIVE CENTRIFUGAL PUMPS



Main Features

Mag drive centrifugal pumps series MGXL are made of thermoplastic materials (Polypropylene or PVDF) and, thanks to their strong and resistant structure, they are suitable for high corrosive fluids and heavy duty applications. The pump casing is machined from a solid block for a great resistance in terms of pressure and temperature and the transmission of the motion occurs through magnetic joints without any mechanical seal. This magnetic drive system guarantees the maximum safety and efficiency reducing risks of leakage and emissions.

Optional:

- Dry-running protection.

Typical Applications:

- High corrosive liquids.
- Toxic, noxious and carcinogenic liquids.

- Materials available: PP / PVDF
- Materials in contact with the liquid: Pump head and impeller PP or PVDF; O-Ring EPDM (standard for PP pumps); Viton (standard for PVDF pumps); Shaft Al_2O_3 99,7%; Bushing PTFEC.
- Max capacity: 130 m³/h.
- Max head: 48m.
- Max temperature: PP: 70 °C –PVDF: 90 °C.
- Flanged or threaded connections according to the pump size.
- Strong structure, maximum resistance to corrosive liquids.

Performance Curve 50 Hz – 2900 RPM

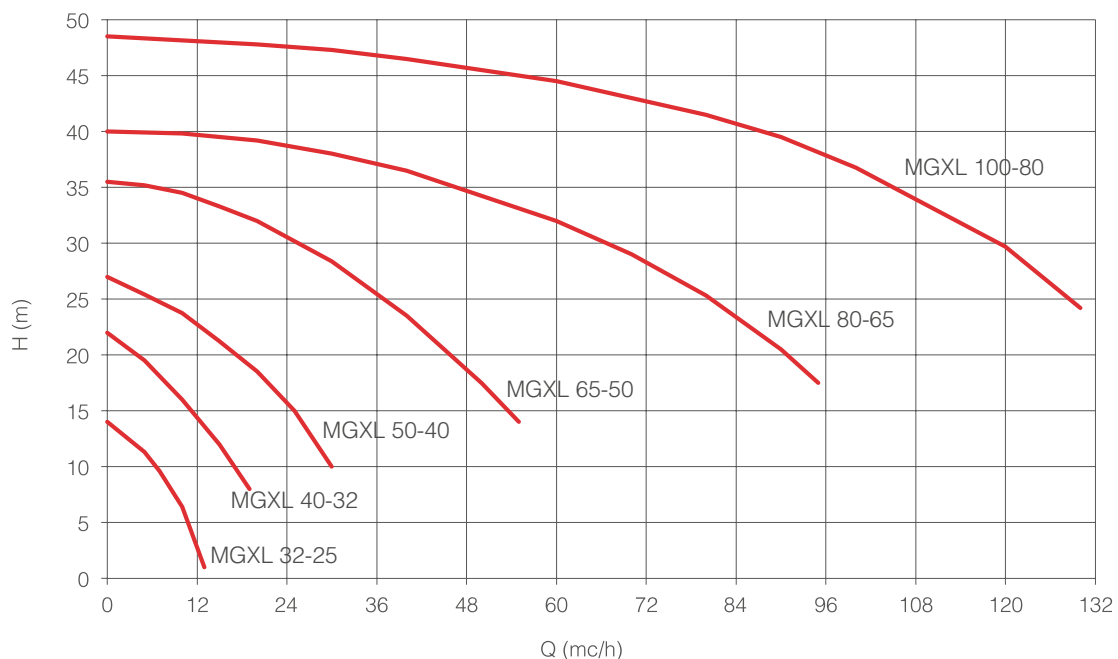

METALLIC MAG-DRIVE CENTRIFUGAL PUMPS



Main Features

Mag drive centrifugal pumps series MG SS are made of AISI 316 or, on request, of other metallic materials (such as HASTELLOY or TITANIUM) and are suitable for hydrocarbons, solvents and dangerous liquids. Thanks to the innovative mag drive design, pumps model MG SS reduce the risks of leakage and emissions and the maintenance costs. The transmission of the motion occurs through magnetic joints without any mechanical seal. This design guarantees the maximum safety and efficiency. The pumped liquid has to be clean and without solids in suspension. Pumps series MG SS 316 are also available in ATEX version for zone 1 and 2 (pump model EM-C).

Standard:

- Threaded in and out connections.

Optional:

- Pump available in other materials (HC 276; Titanium).
- ATEX version
- Explosion proof motor.
- Flanges available.
- Dry-running protection.
- Baseplate.
- Overload switch.

- Materials available: AISI 316;
- Materials in contact with the liquid: casing and impeller: stainless steel AISI 316; O-Ring: EPDM/VITON; Bushing: PTFE/CARBON; Shaft: Hastelloy C276.
- Max flow: 32 m³/h; max head: 24 m.
- Max temperature: 160 °C.
- Max viscosity: 200 cSt.
- Pressure rating: NP 10 at 20 °C.

Performance Curves 50 Hz – 2900 RPM

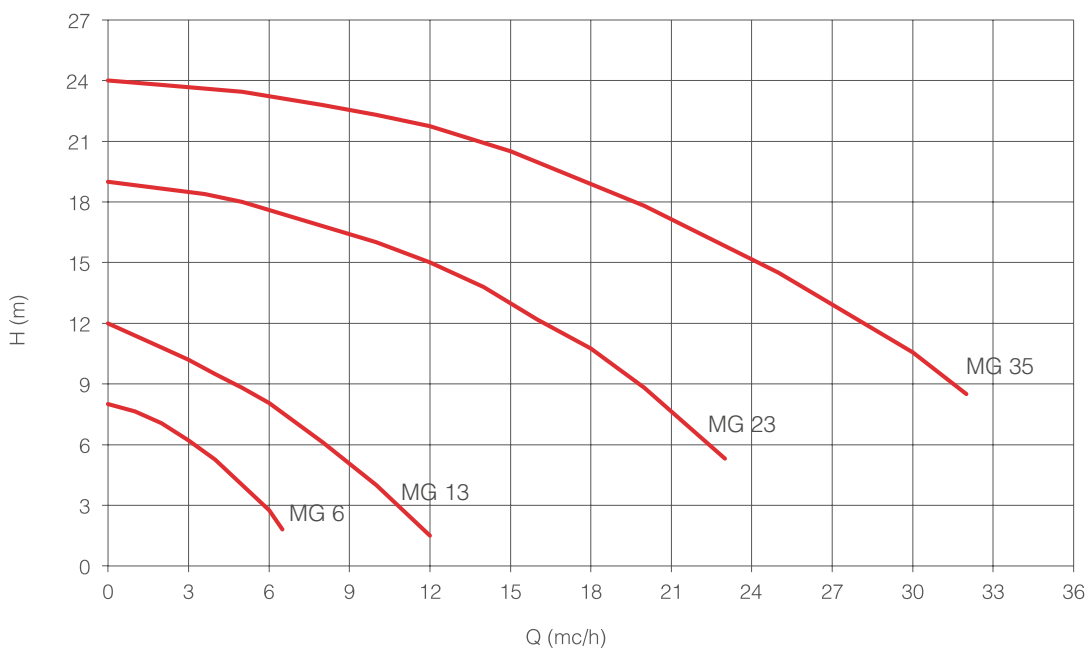

THERMOPLASTIC SELF-PRIMING MAG DRIVE CENTRIFUGAL PUMPS



Standard:

- Gas threaded in and out connections.

Optional:

- Flanges connection.

Main Features

MG-SP pumps combine the typical features of ours mag drive centrifugal pumps with the self-priming capability. At sea level, these pumps can prime up to 6 meters in a very short time. MG-SP pumps can be made of Polypropylene (PP) or PVDF and assure high resistance and chemical compatibility with a large range of corrosive and dangerous fluids. Thanks to the innovative seal-less magnetic drive system, pumps model MG-SP guarantee the maximum safety and efficiently reducing risks of leakage and emissions in the environment and the maintenance costs. The pumped liquid has to be clean, without solids in suspension.

- Materials available: PP or PVDF;
- Materials in contact with the liquid:
Casing and Impeller: PP/PVDF;
O-Ring: EPDM (standard for PP pumps) /
VITON (standard for PVDF pumps);
Static Shaft: Al₂O₃ 99.7%;
Bearing: PTFEC.
- Capacity up to 26 m³/h.
- Head up to 21 m.
- Max temperature: PP: 70 °C - PVDF: 90 °C.
- Max viscosity: 200 cSt.
- Pressure rating: PN6 at 20 °C.
- Self-priming up to 6m at sea level.

Performance Curves 50 Hz – 2900 RPM

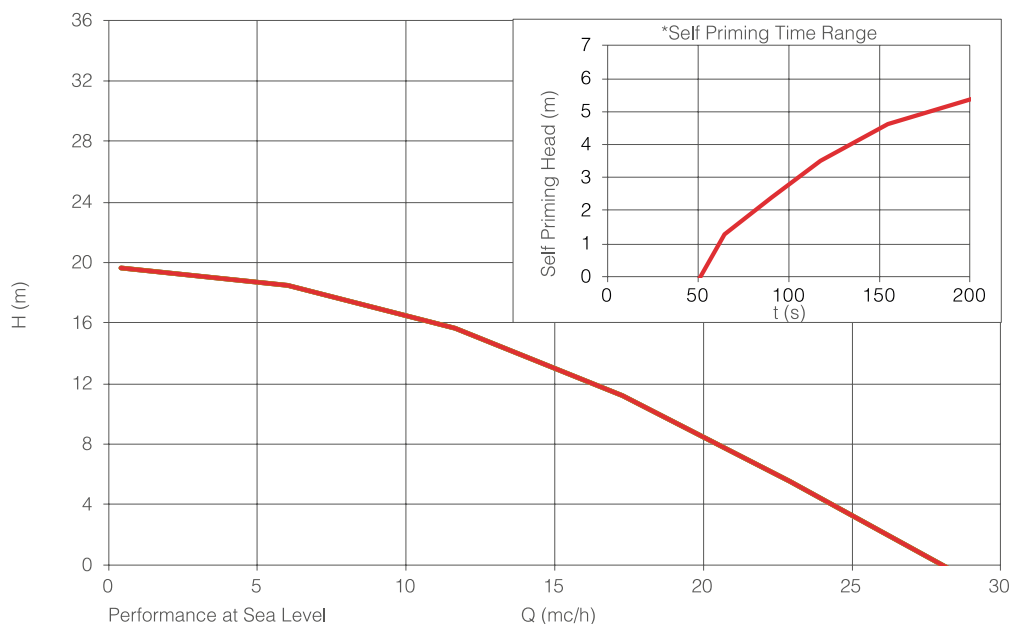

SEAL-LESS MAG DRIVE TURBINE PUMPS

In seal-less magnetic drive turbine pumps, the external magnet is directly connected to the motor shaft and it transmits the torque to the internal magnet.

The magnetic field created produces a rotation without physical contact between the parts and the turbine spins and moves the fluid. The rear casing is placed between the two magnet joints and it hermetically closes the hydraulic part from the motor.

Mangeto can supply three different models of mag drive turbine pumps:

MGT

- Thermoplastic pumps made in PP or PVDF
- Capacity up to 9 m³/h.
- Head up to 50 mlc.

MGT-SP

- Thermoplastic pumps made in PP or PVDF
- Capacity up to 7 m³/h.
- Head up to 25 mlc.
- Machined from a block.
- Self-priming up to 3 m.

MGT-SS

- Metallic pumps made in stainless steel AISI316.
- Capacity up to 7 m³/h.
- Head up to: 80 mlc.

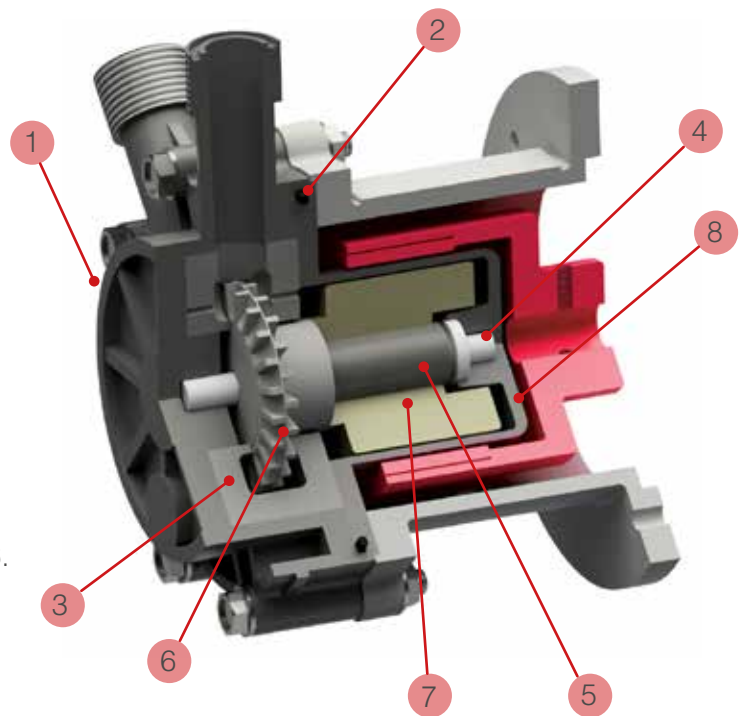

MATERIALS IN CONTACT WITH THE LIQUID			
Part Number / Description	Turbine Pumps		
	MGT	MGT-SP	MGT-SS
1 - Pump Head	PP or PVDF	PP or PVDF	AISI 316
2 - O-Ring	EPDM or Viton	EPDM or Viton	EPDM or Viton
3 - Front and Rear Disc	PP or PVDF	PP or PVDF	PTFEC
4 - Shaft + Ring	Ceramic Al ₂ O ₃ %99,7	Ceramic Al ₂ O ₃ %99,7	HASTELLOY – C276
5 - Bearing	PTFEC	PTFEC	PTFEC
6 - Impeller	PVDF	PVDF	AISI 316
7 - Internal Magnet	PP or PVDF + NdFeB	PP or PVDF + NdFeB	AISI 316 + SmCo
8 - Rear Casing	PP or PVDF	PP or PVDF	AISI 316

THERMOPLASTIC MAG-DRIVE REGENERATIVE TURBINE PUMPS



Mag drive regenerative turbine pumps series MGT are made of thermoplastic materials (polypropylene-PP and PVDF) and are suitable for pumping high corrosive liquids. Thanks to the innovative mag drive system, pumps model MGT reduce risks of leakage and emissions and the maintenance costs. The transmission of the motion occurs through magnetic joints without any mechanical seal. This sealless design guarantees the maximum safety and efficiency. The pumped liquid has to be clean and without solids in suspension.

Standard:

- Gas threaded In and Out connections.
- Static shaft in high purity ceramic.
- Chemical resistant PTFE/carbon sleeve bearings.
- High torque magnetic coupling.
- Direct starting motor.

Optional:

- DIN or ANSI 150 flanges available.
- Baseplate.
- Dry-running protection.

Main Features

- Materials available: PP / PVDF
- Plastic injection moulded.
- Materials in contact with the liquid:
Casing and rear casing: PP/PVDF; Impeller: PVDF;
O-ring: EPDM (standard for PP pumps); Viton (standard for PVDF pumps);
Shaft: Al_2O_3 99,7%;
Bearing: PTFEC.
- Max flow: 9 m³/h; Max head 50 m.
- Temperature: PP: max 70° C - PVDF: max 90 °C.
- Max viscosity: 40 cPs.
- Pressure rating: NP 6.
- It handles up to 20% entrained gas.
- MGT pump resists cavitation.

Performance Curves 50 Hz – 2900 RPM

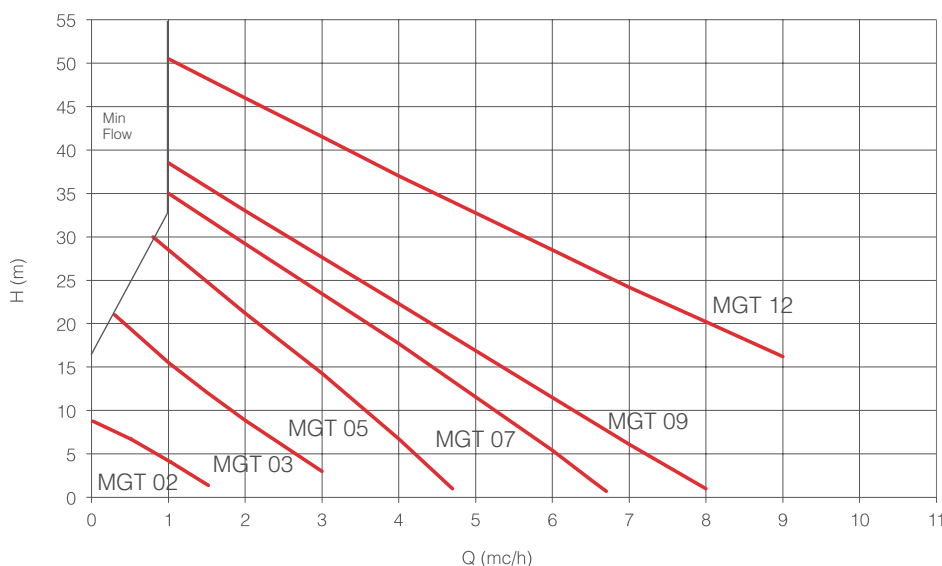

THERMOPLASTIC MAG-DRIVE REGENERATIVE TURBINE PUMPS SELF-PRIMING



MGT-SP pumps can prime up to 5 m with water at ambient temperature. The casing is made from a PP solid machined block and the impeller in PVDF for maximum chemical resistance. The casing is machined from a solid block. The impeller in PVDF is self-balanced to eliminate thrust bearing wear and it is separate to minimize the maintenance costs. This kind of pump offers maximum resistance withstanding also external corrosion. It handles up to 20% entrained gas and resists cavitation.

Standard:

- Gas threaded in and out connections.
- Static shaft in high purity ceramic.
- Chemical resistant PTFE/carbon sleeve bearings.
- High torque magnetic coupling.
- Direct starting motor.

Main Features

- Max flow: 6 m³/h; max head 28 m.
- Max temperature: PP: 70° C - PVDF: 90 °C.
- High torque magnetic coupling.
- Chemical resistant PTFE/carbon sleeve bearings.
- Static shaft in high purity ceramic.
- Direct starting motor.

Optional:

- ANSI 150 flanges available.
- Baseplate.

Performance Curves 50 Hz – 2900 RPM

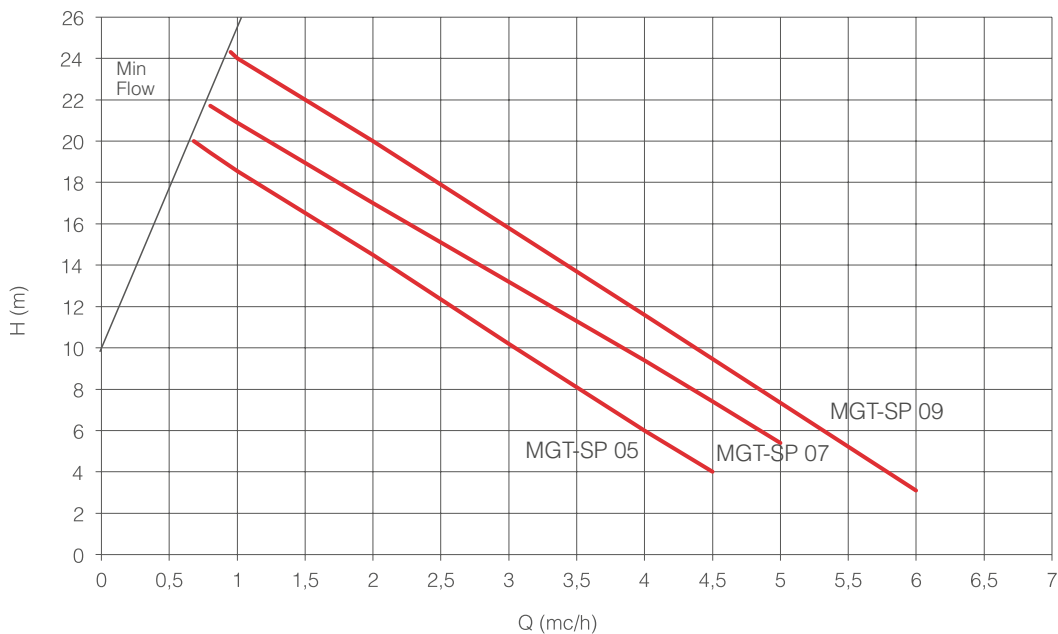

METALLIC MAG-DRIVE REGENERATIVE TURBINE PUMPS



Main Features

Mag drive regenerative turbine pumps series MGT-SS are made of AISI 316 or, if requested, of other metallic materials (HASTELLOY or TITANIUM) and are suitable for solvents, hydrocarbons, dangerous and inflammable liquids. Thanks to the innovative mag drive system, pumps model MGT-SS reduce the risks of leakage and emissions and maintenance costs. The transmission of the motion occurs through magnetic joints without any mechanical seal. This design guarantees the maximum hermetic safety and efficiency. The pumped liquid has to be clean and without solids in suspension. Pumps series MGT-SS are also available in ATEX version for zone 1 and 2 (pump model EM-T).

Standard:

- Static shaft in HC 276.
- Chemical resistant PTFE/Carbon sleeve bearings standard.
- High torque magnetic coupling.
- Direct starting motors.

Optional:

- ANSI 300 flanges available.
- ATEX version.
- Explosion proof motor.
- Dry-running protection.
- Baseplate.

- High head / low flow capability minimizes by-pass requirements.
- Materials available: AISI 316;
- Materials in contact with the liquid:
Casing and impeller: stainless steel AISI 316;
O-ring EPDM/VITON;
Bushing: PTFEC; shaft: Hastelloy C276.
- Max flow 7 m³/h; max head 80 mlc.
- Max Temperature: 160 °C.
- Pressure Rating NP 25 at 20 °C.
- Impeller design handles up to 20% entrained gas.
- Ideal for pumping liquefied gas.

Performance Curves 50 Hz – 2900 RPM

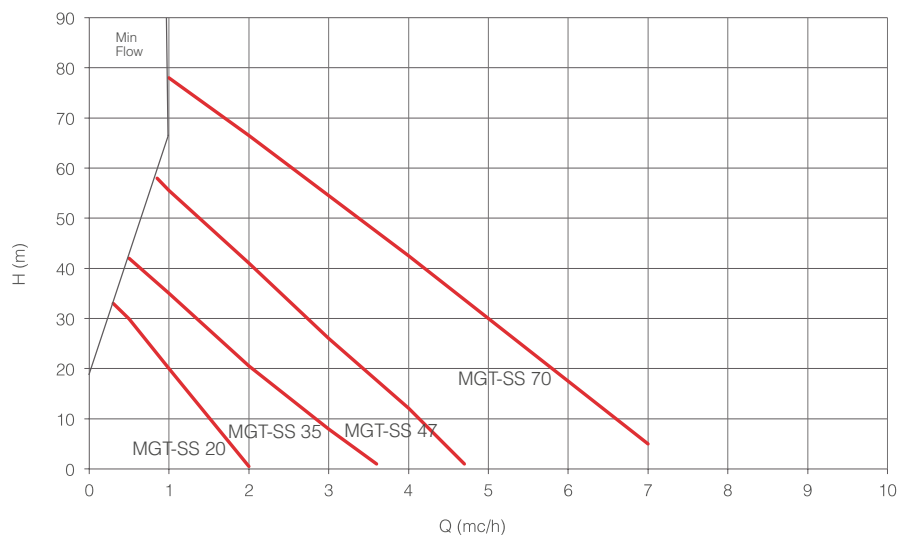

SEAL-LESS MAG DRIVE VANE PUMPS

In seal-less magnetic drive vane pumps, the external magnet is directly connected to the motor shaft and it transmits the torque to the internal magnet. The magnetic field created produces a rotation without physical contact between the parts and the rotor spins. The vanes inside the rotor slide in and out of their seat and they move the fluid. The rear casing is placed between the two magnet joints and it hermetically closes the hydraulic part from the motor.

Mangeto can supply two different models of volumetric pumps:

MGP

- Thermoplastic pumps made in PP or PVDF
- Capacity up to 1000L/h.
- Pressure up to 5 bar.

MGP-S

- Metallic pumps made in stainless steel AISI316.
- Capacity up to 2100L/h.
- Pressure up to: 13 bar.
- Dry self-priming.

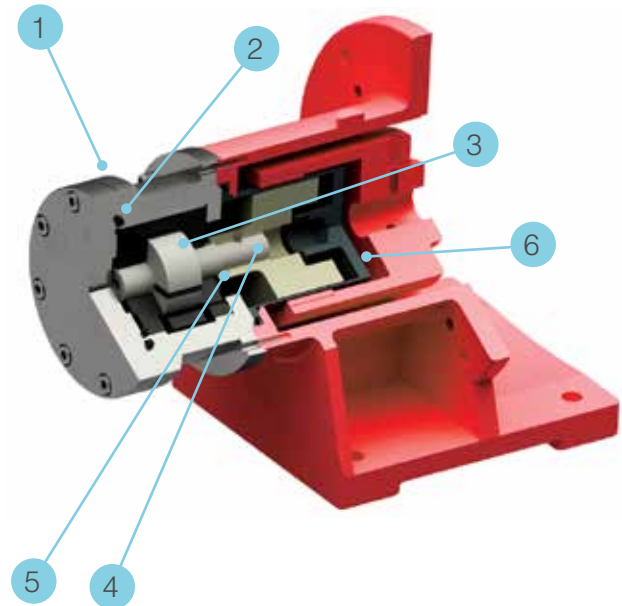

MATERIALS IN CONTACT WITH THE LIQUID		
Part Number / Description	Vane Pumps	
	MGT	MGT-SP
1 - Pump Body + Cover	PP or PVDF	AISI 316
2 - O-Ring	EPDM or Viton	EPDM or Viton
3 - Flanges Stator Vanes + Pins	PVDF+ Grafit	Graphite
4 - Rotor Shaft	PVDF	AISI 316
5 - Internal Magnet	PP or PVDF + NdFeB	AISI 316 + SmCo
6 - Rear Casing	PP or PVDF	AISI 316

THERMOPLASTIC MAG-DRIVE ROTARY VANE PUMPS



Main Features

Mag drive rotary vane pumps series HPP-HPF are made of thermoplastic materials (PP/PVDF) and are suitable for corrosive liquids, alkalis, toxic, noxious and carcinogenic fluids. Thanks to the innovative mag drive system, pumps model HPP-HPF reduce the risks of leakage and the maintenance costs. HPP-HPF pumps are useful for low flow and high head applications such as Pilot Plants and Sampling.

System Pressure:

- 8 bar.

Standard:

- High torque magnetic coupling.
- Direct starting motor.

Optional:

- Flanges available.
- Dry-running protection.
- Baseplate.

- PP, PVDF
- Materials in contact with the liquid:
Casing, end cover, internal magnet and rear casing: PP/PVDF;
O-ring: EPDM (standard for PP pumps);
VITON (standard for PVDF pumps).
- Graphite Stator.
- Rotor shaft: PVDF
- Max flow: 1000L/h.
- Max pressure: 5 bar.
- Temperature: PP: max 70 °C - PVDF: max 90 °C.

Performance Curves 50 Hz – 1450 RPM

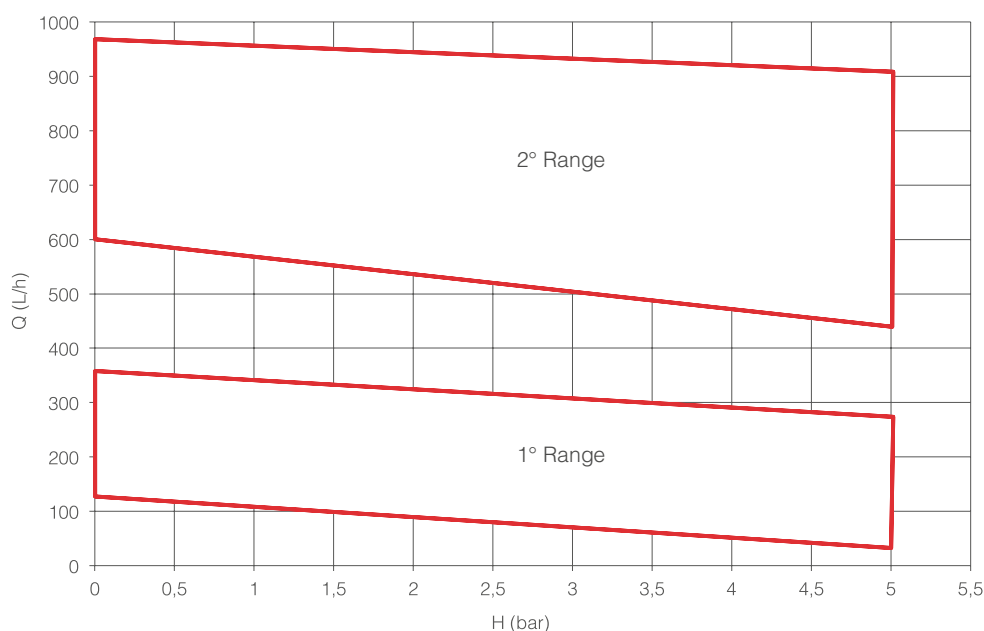

METALLIC ROTARY VANE MAG-DRIVE PUMPS DRY SELF-PRIMING



Main Features

Rotary vane mag drive pumps series HTP are made of AISI 316 or, if requested, of other metallic materials (Titanium and Hastelloy) and are suitable for hydrocarbons, solvents, heat transfer oils, refrigerants, cryogenics and radioactive liquids. Thanks to the innovative mag drive system, pumps model HTP reduce the risks of leakage and emissions and the maintenance costs. HTP pumps are useful for low flow and high head applications such as Pilot Plants, Sampling and Flushing of mechanical seals. Especially designed for thin non-lubricating liquids and/or high differential pressure. Pumps series HTP are also available in ATEX version for zone 1 and 2 (pump model EM-P).

Standard:

- High torque magnetic coupling.
- Direct starting motor.

Optional:

- Flanges available.
- Dry-running protection.
- Baseplate.
- ATEX version (Pump mode. EM-P).
- Explosion proof motor.

- Materials available: AISI 316.
- Materials in contact with the liquid:
Pump body, end cover and rotor: AISI 316;
O-ring: EPDM/VITON; carbon graphite stator.
- Max flow: 2100L/h.
- Max pressure: 13 bar.
- Temperature range: from - 70 °C to + 200 °C.
- Max viscosity: 2000 cPs.
- System Pressure: 25 bar.

Performance Curves 50 Hz – 1450 RPM

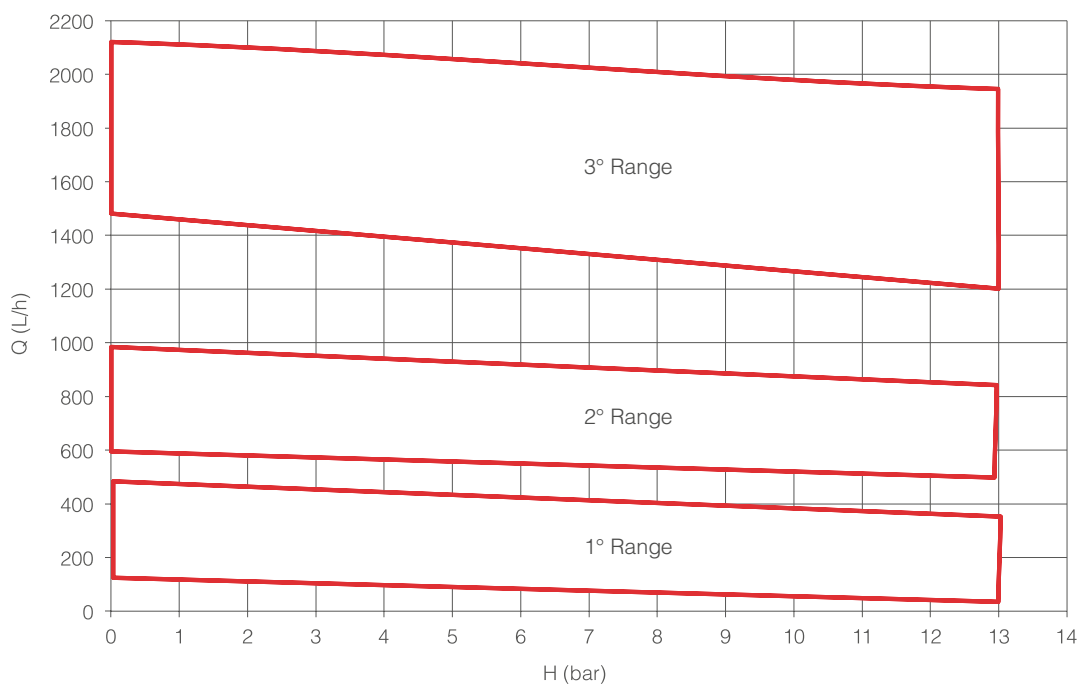

MECHANICAL SEAL CENTRIFUGAL PUMPS

Mechanical seal centrifugal pumps are the right solution for applications involving solids in the liquid because their design with open impeller allows to pump dirty liquids and fluids with high viscosity. The seal in mechanical seal pumps is composed by a static ring and a rotating ring placed on the pump shaft which is directly coupled to the motor shaft. The two surfaces sliding together need to be lubricated and the seal lubricant is the liquid itself that is being pumped.

Mangeto can supply the following model of mechanical seal pump:

MS

- Thermoplastic pumps made in PP or PVDF
- Capacity up to 58 m³/h.
- Head up to 38 m.
- Two different kind of mechanical seal available: lip seal for model MS 95-10, internal PTFE bellow mechanical seal for all the other pump sizes.

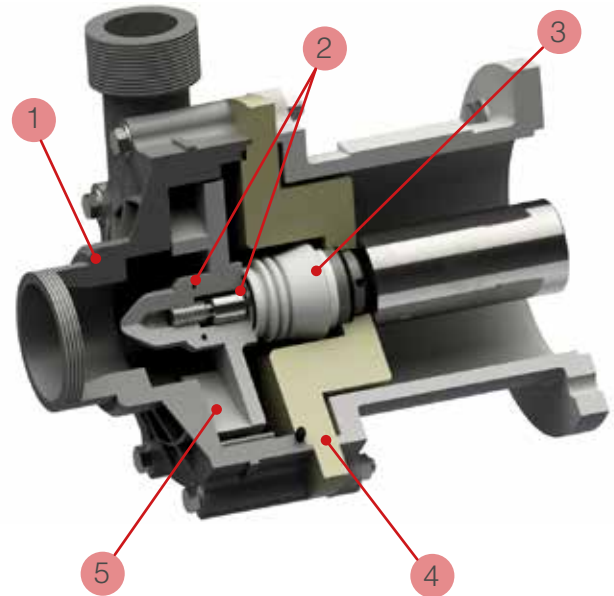

MATERIALS IN CONTACT WITH THE LIQUID	
Part Number / Description	Mechanical Seal Pumps
	MS
1 - Pump Head	PP or PVDF
2 - O-Ring	EPDM or Viton
3 - Mechanical Seal	PTFE + Al ₂ O ₃
4 - Cover	PP or PVDF
5 - Impeller and Impeller Nut	PP or PVDF + NdFeB

MECHANICAL SEAL CENTRIFUGAL PUMPS



Main Features

Centrifugal pumps series MS with mechanical seal are made of thermoplastic materials (Polypropylene and PVDF) and are suitable for high corrosive liquids containing solids in suspension. The seal of pumps MS size 95-10 is guaranteed by a special elastomeric lip seal, while all the other pump sizes (from size 110 to 170) are equipped with an internal PTFE bellows mechanical seal (sic/ceramic), which is manufactured by Ekin Endüstriyel.

- Materials available: PP / PVDF
- Flow up to 60 m³/h; Head up to 38 m.
- Temperature: PP: max 70 °C - PVDF: max 90 °C.
- Max viscosity: 200 cSt.
- Pressure rating: NP 6 at 20 °C.
- Lip seal for pumps size 95-10; internal PTFE bellows mechanical seal for all the other sizes.
- Suitable for high corrosive liquids containing solids in suspension.

Standard:

- Gas threaded in and out connections.
- Direct starting motor

Optional:

- Flanges available.
- Dry-running protection.
- Baseplate.

Performance Curves 50 Hz – 2900 RPM

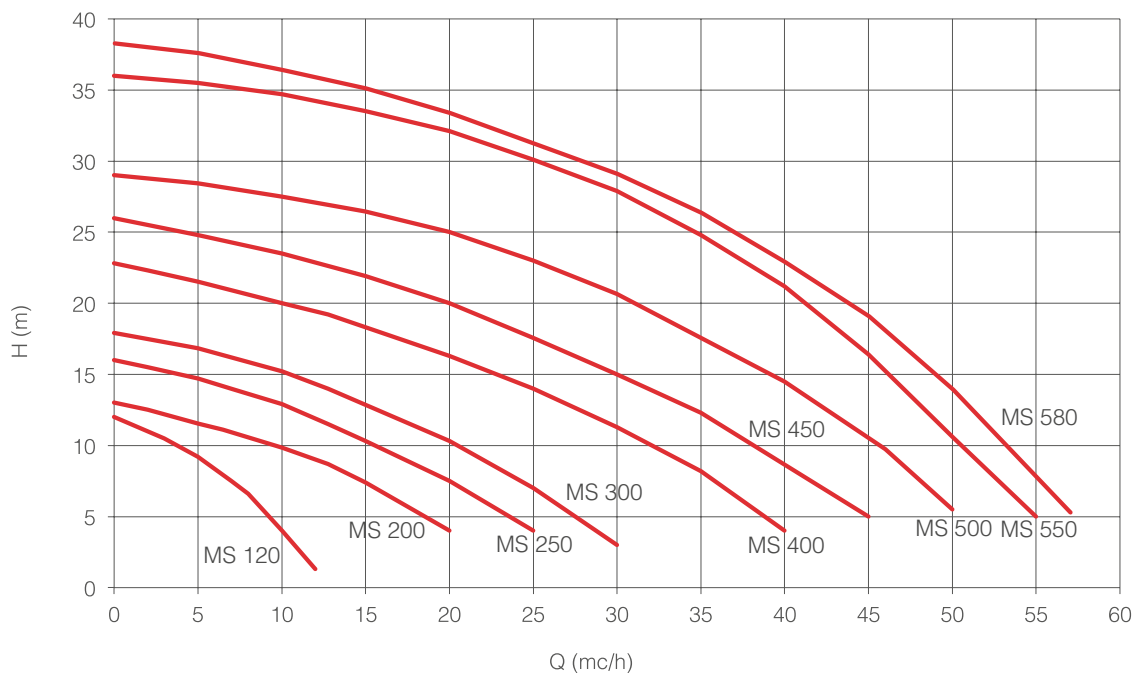

VERTICAL CENTRIFUGAL PUMPS

Vertical centrifugal pumps are suitable for installations with pump immersed directly in the tank. Mangeto can supply the following models of vertical pumps:

VS

- Thermoplastic pumps made in PP or PVDF
- Capacity up to 40 m³/h.
- Head up to 22 mlc.
- Monobloc pump with semi open-impeller.
- Suitable for high corrosive liquids with solids in suspension.
- Maximum length 1000 mm.

VS-SS

- Vertical centrifugal cantilever pumps.
- Made in AISI316.
- Capacity up to 24 m³/h.
- Head up to 26 mlc.
- Especially designed for the production of PCBs.

VSXL

- Thermoplastic pumps made in PP or PVDF
- Capacity up to 57 m³/h.
- Head up to 39 mlc.
- Centrifugal pump with coupling and semi open-impeller.
- Suitable for high corrosive liquids with solids in suspension.
- Maximum column length 2000 mm.

MG-V

- Vertical magnetic drive pumps.
- Thermoplastic pumps made in PP or PVDF
- Capacity up to 23 m³/h.
- Head up to 20 mlc.
- Column length: 320 mm.

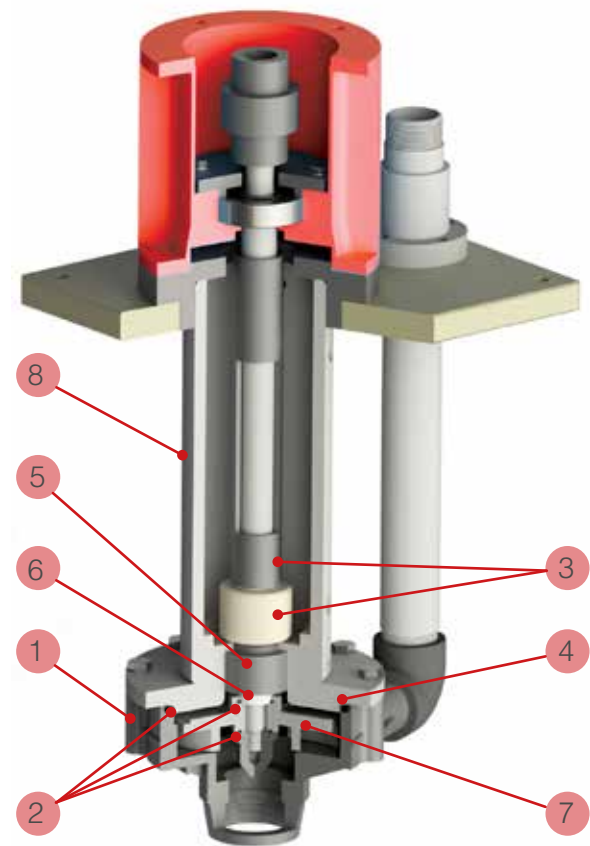

MATERIALS IN CONTACT WITH THE LIQUID		
Part Number / Description	Vertical Pumps	
	VS	VSXL
1 - Pump Head	PP or PVDF	PP or PVDF
2 - O-Ring	EPDM or Viton	EPDM or Viton
3 - Shaft Covering	PP	PP
4 - Cover	PP or PVDF	PP or PVDF
5 - Bushing	PTFEC	PTFEC
6 - Wear Bushing	Al ₂ O ₃	Al ₂ O ₃
7 - Impeller	PP or PVDF	PP or PVDF
8 - Column	PP or PVDF	PP or PVDF

VERTICAL CENTRIFUGAL PUMPS



- Centrifugal monoblock pump.
- Materials available: PP, PVDF.
- Max flow: 40 m³/h;
- Max head: 22 m.
- Temperature: PP: max 70 °C; PVDF: max 90 °C.
- Suitable for high corrosive liquids containing solids in suspension.
- Length of the column: from 500 to 1000 mm.

Standard:

- Threaded in and out connections.

Optional:

- Dry-running protection.
- Flanges available.
- Suction strainer.

Performance Curves 50 Hz – 2900 RPM

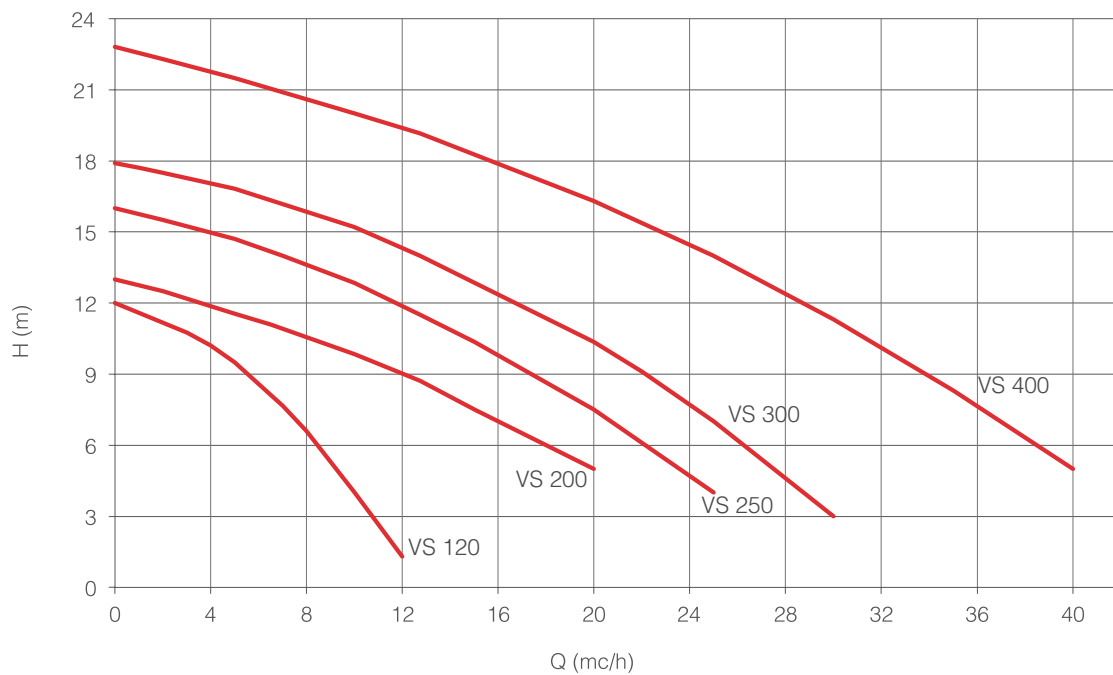

VERTICAL CENTRIFUGAL PUMPS



- Centrifugal pump with coupling.
- Materials available: PP, PVDF
- Max flow: 57 m³/h; Max head: 39 m.
- Temperature: PP: max 70 °C; PVDF: max 90 °C.
- Suitable for high corrosive liquids containing solids in suspension.
- Length of the column: from 500 to 2000 mm.

Standard:

- Threaded in and out connections.

Optional:

- Dry-running protection.
- Flanges available.
- Suction strainer.

Performance Curves 50 Hz – 2900 RPM

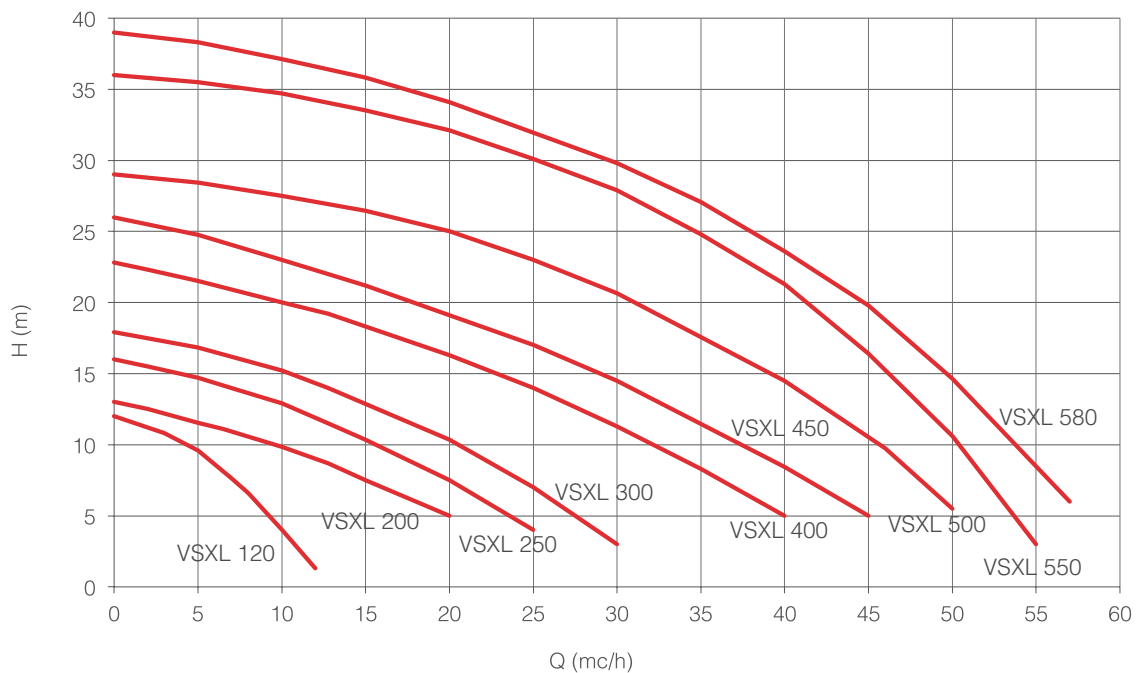

VERTICAL MAG DRIVE CENTRIFUGAL PUMPS



Main Features

Vertical mag drive centrifugal pumps series MG-V are made of thermoplastic materials (Polypropylene and PVDF) and are suitable to handle chemicals and corrosive liquids. This kind of pump has been designed for a vertical submerged installation, providing high reliability for intank and sump applications. MG-V are seal-less magnetic drive pumps without any kind of labyrinth or mechanical seal. The column of the pump is hermetically sealed and it allows complete isolation of the motor, the extension shaft and external magnet of the pump from the process liquid.

- Materials available: PP /PVDF
- Materials in contact with the liquid:
Casing and impeller: PP/PVDF;
O-Ring: EPDM (standard for PP pumps);
VITON (standard for PVDF pumps);
Shaft: Al₂O₃ 99,7%;
Bushing: PTFEC.
- Max flow: 22 m³/h.
- Max head 20 m.
- Temperature: PP: max 70 °C
PVDF: max 90 °C.
- Compact design.
- Column length: 320 mm.

Optional:

- Dry running protection.
- Also available with bracket suitable for NEMA motors.

Performance Curves 50 Hz – 2900 RPM

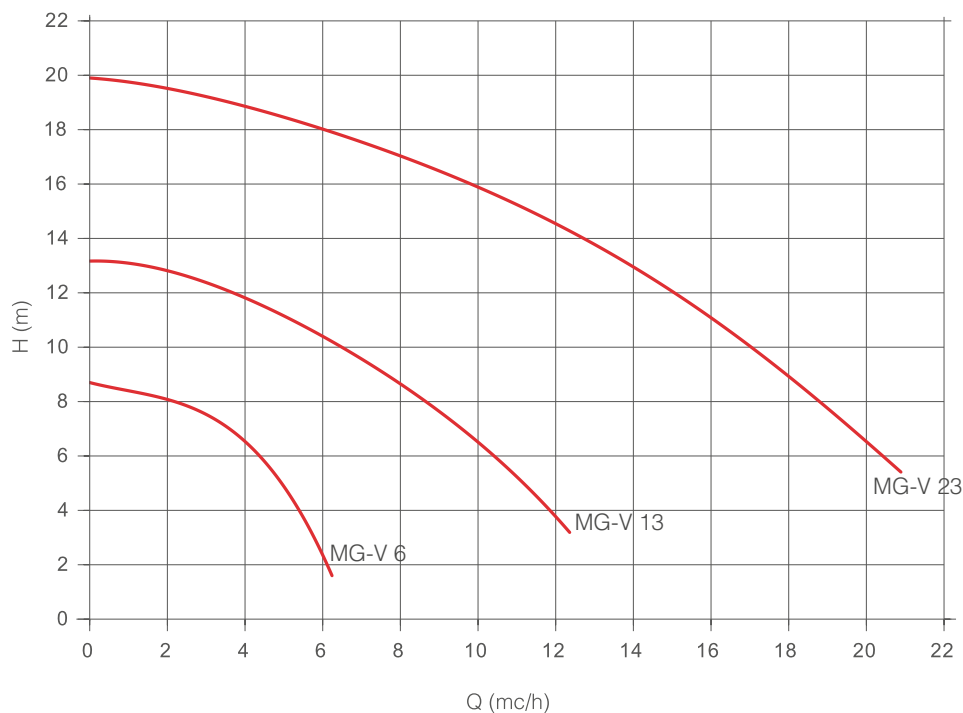

CENTRIFUGAL VERTICAL CANTILEVER PUMPS



Features

- Materials available: AISI 316 or Titanium.
- Max flow: 24 m³/h.
- Max head: 26 m.
- Fume labyrinth seal. A combined system of labyrinth, rings and PTFE lip seal guarantees tightness against gas and vapours.
- Impeller with low axial thrust.
- Suitable for corrosive liquids containing solids.
- Especially designed for use in the production of printed circuit boards (PCB). AISI 316 version is suitable for potassium permanganate applications at 90 °C.
- Titanium version is suitable for "Black Oxide".
- Two different types available: VS-SS 1 for tank transfer and VS-SS 2 used as a boosting pump. VS-SS 2 model should be installed in the same tank where VS-SS 1. This provides a tight system which prevents any leaks.

Performance Curves 50 Hz – 2900 RPM

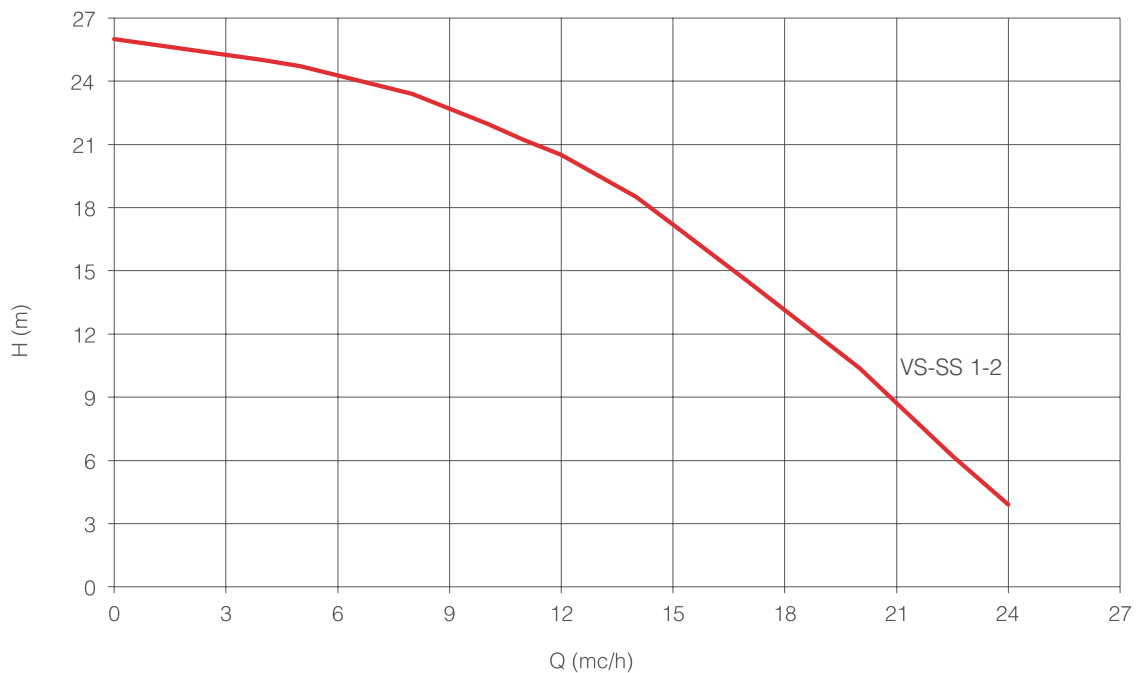

ATEX PUMPS

For pumping applications in potentially explosive atmospheres Mangeto offers ATEX certified pumps suitable for zone 1 II 2G c Tx and zone 2 II 3G c Tx.

All our Atex pumps comply with the technical and safety requirements of ATEX directive 2014/34/EU.

The Atex Pumps Available

Only for ATEX zone 2.
(See pumps model MG PP/PVDF, MGT and MGP)

For Atex zone 1 and 2.
(See pump model MG SS316)



For Atex zone 1 and 2.
(See pump model MGT-SS)

For Atex zone 1 and 2.
(See pump model MGP-S)



ACCESSORIES

Dry-Running Protection

The installation of W 01 Emirel prevents expensive damage to pumps because it avoids the dryrunning working, the closed discharge and the blocked suction. We recommend the use of this instrument to unload tank truck or every other application when it's not certain if the liquid is constantly present in the pipes. This device checks constantly the active power of the motor, that is the medium value of the instantaneous power absorbed by the pump, through the reception of information about the voltage and about the voltage variations. Through a set point and a timer, which are adjustable, it's possible to set the minimum power and the triggering time of the device.

If the power goes under the established value, the pump stops and the device must be switched on again manually.

In case of continuous intervention on the apparatus, check the presence of liquid and/or the correct functioning of the plant to find the cause of working of the device.



Flanges



Magnetopumps are usually supplied with threaded connections. Upon request we can also supply DIN or ANSI flanges for thermoplastic pumps (flat stub + free flange) and welded DIN or ANSI flanges for AISI316 pumps.

magneto



+441217900115



sales@magnetopump.com



www.magnetopump.com



UNITED KINGDOM
Birmingham